

## Protection Circuits

Protection circuits are an extremely important safety feature of any well designed circuit using a primary (non-rechargeable) cell in conjunction with another power source. The [UL](#) standard calls for either two diodes in series, or a resistor and diode in series, to prevent the battery from being charged by the main power source. This diagram illustrates these two different options:

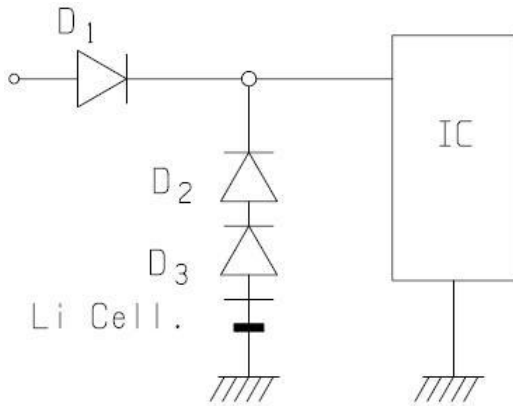

*Protection Circuit A*

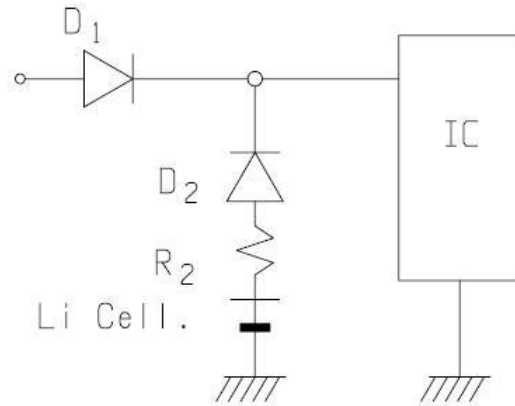

*Protection Circuit B*

Protection circuits for secondary (rechargeable) cells serve a different purpose, since they must allow currents to flow in both directions so that they may both charge and discharge. The protection circuits for rechargeable batteries typically serve to prevent overcharging and over-discharging, which is important for safety as these batteries are usually very powerful, and could cause serious damage if they were to malfunction without any protection circuit. Some new types of cells, such as rechargeable lithium-ion batteries, can be purchased containing their own individual protection circuit modules on the ends of each cell.